

TRUNCATED MODULES AND LINEAR PRESENTATIONS OF VECTOR BUNDLES

ADA BORALEVI, DANIELE FAENZI, AND PAOLO LELLA

ABSTRACT. We give a new method to construct linear spaces of matrices of constant rank, based on truncated graded cohomology modules of certain vector bundles. Our method allows one to produce several new examples, and provides an alternative point of view on the existing ones.

INTRODUCTION

A space of matrices of constant rank is a vector subspace V , say of dimension $n + 1$, of the set $M_{a,b}(\mathbf{k})$ of matrices of size $a \times b$ over a field \mathbf{k} , such that any element of $V \setminus \{0\}$ has fixed rank r . It is a classical problem, rooted in work of Kronecker and Weierstrass, to look for examples of such spaces of matrices, and to give relations among the possible values of the parameters a, b, r, n .

One can see V as an $a \times b$ matrix whose entries are linear forms (a “linear matrix”), and interpret the cokernel as a vector space varying smoothly (i.e. a vector bundle) over \mathbb{P}^n . In [EH88, IL99, Syl86] the relation between matrices of constant rank and the study of vector bundles on \mathbb{P}^n and their invariants was first studied in detail. This interplay was pushed one step further in [BFM13, BM15], where the matrix of constant rank was interpreted as a 2-extension from the two vector bundles given by its cokernel and its kernel. This allowed the construction of skew-symmetric matrices of linear forms in 4 variables of size 14×14 and corank 2, beyond the previous “record” of [Wes96]. In this paper we turn the tide once again and introduce a new effective method to construct linear matrices of constant rank; our method not only allows one to produce new examples beyond previously known techniques, but it also provides an alternative point of view on the existing examples.

The starting point of our analysis is that linear matrices of relatively small size can be cooked up with two ingredients, namely two finitely generated graded modules \mathbf{E} and \mathbf{M} over the ring $R = \mathbf{k}[x_0, \dots, x_n]$, admitting a linear resolution up to a certain step. Here, the module \mathbf{G} should be thought of as a “small” modification of \mathbf{E} , namely \mathbf{G} should be Artinian. Then, under suitable conditions, the kernel $\mathbf{F} = \ker(\mu)$ of a surjective map $\mu : \mathbf{E} \rightarrow \mathbf{G}$ will only have linear and quadratic syzygies; by imposing further constraints we obtain a presentation matrix for \mathbf{F} that is not only linear, but also of smaller size than that of \mathbf{E} , as the presentation matrix of \mathbf{G} is “subtracted” from that of \mathbf{E} . The key idea here is that, in order for \mathbf{E} to fit our purpose, it is necessary to *truncate* it above a certain range, typically its regularity, which ensures linearity of the resolution, while leaving the rank of the matrix presenting \mathbf{E} unchanged. To connect this result with linear matrices of constant rank, one takes \mathbf{E} and \mathbf{G} such that their sheafifications are vector bundles over \mathbb{P}^n ; this, together with one more technical assumption, guarantees that the presentation matrix of \mathbf{E} ,

2010 *Mathematics Subject Classification.* 13D02, 16W50, 15A30, 14J60.

Key words and phrases. Graded truncated module, linear presentation, matrix of constant rank, vector bundle, instanton bundle.

Research partially supported by MIUR funds, PRIN 2010-2011 project “Geometria delle varietà algebriche”, FIRB 2012 “Moduli spaces and Applications”, GEOLMI ANR-11-BS03-0011, J. Draisma’s Vidi grant from the Netherlands Organization for Scientific Research (NWO) and Università degli Studi di Trieste – FRA 2011 project “Geometria e topologia delle varietà”. All authors are members of GNSAGA.

as well as that of any of its higher truncation, actually has constant rank. This is the content of our two main results, Theorems 1.1 and 1.2.

In order to obtain interesting matrices via our method, we analyze Artinian modules \mathbf{G} with pure resolution, exploiting some basic results of Boij-Söderberg theory [BS08, EFW11, ES09, ESS]. Note that the choice of where one needs to truncate is arbitrary here; in this sense we define a tree associated with any linearly presented module \mathbf{E} , rooted in \mathbf{E} , whose nodes are the possible forms of linear matrices whose sheafified cokernel is $\tilde{\mathbf{E}}$, and whose edges correspond to the Artinian modules with pure resolution that we use in the construction of the matrices.

To appreciate the validity of our approach one should compare it with previously known techniques, namely “ad hoc” constructions and projection from bigger size matrices. Our graded modules go above and beyond, and in particular allow one to achieve the construction of matrices with “small constant corank” with respect to the size, which is where the projection method fails, and which is one of the hardest tasks in this type of problems, especially so when $n \geq 3$. (See section 2 for such a comparison, as well as a more precise definition of small corank.)

In addition to this, via our algorithms one can recover some sought-after examples of $n + 1$ -dimensional spaces of matrices of size $(kn + 1) \times (kn + n - 1)$ and rank kn , that are the subject of the entire paper [Wes90]. The reader can find an explicit example in sections 4.1.

One of the goals of this paper is to provide a list of matrices of constant rank arising from vector bundles over projective spaces. We concentrate here on the most classical constructions (instantons, null-correlation bundles and so forth). To our knowledge however, among the examples of matrices of constant rank that we construct from these bundles, very few were known before. All this is developed in §4.

The last subject are linear matrices of constant rank with extra symmetry properties: we examine the conditions needed for a constant rank matrix A constructed with our method to be skew-symmetric in a suitable basis (we call such matrix skew-symmetrizable). This is tightly related with the results of [BFM13]; indeed the outcomes of this section should be seen as a parallel of those of [BFM13] which complements and explains the techniques used there, relying on commutative algebra rather than derived categories.

Another advantage of our technique is that it is algorithmic, and can be implemented in a very efficient way, as computations sometimes work even beyond their theoretical scope. This not only provides a detailed explanation of the algorithm appearing in [BFM13, Appendix A], but allows to construct infinitely many examples of skew-symmetric 10×10 matrices of constant rank 8 in 4 variables; up to now, the only example of such was that of [Wes96].

Finally, let us note that all these examples, and many more, can be explicitly constructed thanks to the *Macaulay2* [GS] package `ConstantRankMatrices` implementing our algorithms. The interested reader can find it at the website www.paololella.it/EN/Publications.html.

1. MAIN RESULTS

1.1. Notation and preliminaries. Let $R := \mathbf{k}[x_0, \dots, x_n]$ be a homogeneous polynomial ring over an algebraically closed field \mathbf{k} of characteristic other than 2. The ring R comes with a grading $R = R_0 \oplus R_1 \oplus \dots$, with $R_0 = \mathbf{k}$, and is generated by R_1 as a \mathbf{k} -algebra.

All R -modules here are finitely generated and graded. If \mathbf{M} is such a module, and p, q are integer numbers, we denote by \mathbf{M}_p the p -th *graded component* of \mathbf{M} , so that $\mathbf{M} = \bigoplus_p \mathbf{M}_p$, and by $\mathbf{M}(q)$ the q th *shift* of \mathbf{M} , defined by the formula $\mathbf{M}(q)_p = \mathbf{M}_{p+q}$. Finally, the module $\mathbf{M}_{\geq m} = \bigoplus_{p \geq m} \mathbf{M}_p$ is the *truncation* of \mathbf{M} at degree m .

A module \mathbf{M} is *free* if $\mathbf{M} \simeq \bigoplus_i R(q_i)$ for suitable q_i . Given any other finitely generated graded R -module \mathbf{N} , we write $\text{Hom}_R(\mathbf{M}, \mathbf{N})$ for the set of homogeneous maps of all degrees, which is again a graded module, graded by the degrees of the maps. Since graded free resolutions exist, this construction extends to a grading on the modules $\text{Ext}_R^q(\mathbf{M}, \mathbf{N})$. The same holds true for $\mathbf{M} \otimes_R \mathbf{N}$ and $\text{Tor}(\mathbf{M}, \mathbf{N})$. For any R -module \mathbf{M} , we denote by $\beta_{i,j}(\mathbf{M})$ the graded Betti numbers of the

minimal resolution of \mathbf{M} , i.e.

$$\cdots \longrightarrow \bigoplus_{j_i} R(-j_i)^{\beta_{i,j_i}} \longrightarrow \cdots \longrightarrow \bigoplus_{j_1} R(-j_1)^{\beta_{1,j_1}} \longrightarrow \bigoplus_{j_0} R(-j_0)^{\beta_{0,j_0}} \longrightarrow \mathbf{M} \longrightarrow 0.$$

For $p \gg 0$, the Hilbert function $\dim_{\mathbf{k}} \mathbf{M}_p$ is a polynomial in p . The degree of this polynomial, increased by 1, is $\dim \mathbf{M}$, the *dimension* of \mathbf{M} . The *degree* of \mathbf{M} is by definition $(\dim \mathbf{M}!)$ times the leading coefficient of this polynomial.

We say that \mathbf{M} has *m-linear resolution* over R if the minimal graded free resolution of \mathbf{M} reads:

$$\cdots \longrightarrow R(-m-2)^{\beta_{2,m+2}} \longrightarrow R(-m-1)^{\beta_{1,m+1}} \longrightarrow R(-m)^{\beta_{0,m}} \longrightarrow \mathbf{M} \longrightarrow 0$$

for suitable integers $\beta_{i,m+i}$. In other words, \mathbf{M} has a *m-linear resolution* if $\mathbf{M}_r = 0$ for $r < m$, \mathbf{M} is generated by \mathbf{M}_m , and \mathbf{M} has a resolution where all the maps are represented by matrices of linear forms. In the case where only the first k maps are matrices of linear forms then \mathbf{M} is said to be *m-linear presented up to order k*, or just *linearly presented* when $k = 1$.

A module \mathbf{M} is *m-regular* if, for all p , the local cohomology groups $H_{\mathfrak{m}}^p(\mathbf{M})_r$ vanish for $r = m-p+1$ and also $H_{\mathfrak{m}}^0(\mathbf{M})_r = 0$ for all $r \geq m+1$. The regularity of a module is denoted by $\text{reg}(\mathbf{M})$ and can be computed from the Betti numbers as $\max\{j-i \mid \beta_{i,j} \neq 0\}$. Note that $\mathbf{M}_{\geq \text{reg}(\mathbf{M})}$ always has *m-linear resolution*.

1.2. Main Theorems. Let \mathbf{E} and \mathbf{G} be finitely generated graded R -modules with minimal graded free resolutions as follows:

$$\begin{aligned} \cdots &\longrightarrow \mathbf{E}^1 \xrightarrow{e_1} \mathbf{E}^0 \xrightarrow{e_0} \mathbf{E} \longrightarrow 0, \text{ and} \\ \cdots &\longrightarrow \mathbf{G}^1 \xrightarrow{g_1} \mathbf{G}^0 \xrightarrow{g_0} \mathbf{G} \longrightarrow 0. \end{aligned}$$

A morphism $\mu : \mathbf{E} \rightarrow \mathbf{G}$ induces maps $\mu^i : \mathbf{E}^i \rightarrow \mathbf{G}^i$, determined up to chain homotopy. Note that, in case \mathbf{E} and \mathbf{G} are linearly presented up to order j , the maps μ^i are uniquely determined for $i \leq j-1$.

Theorem 1.1. *Let \mathbf{E} and \mathbf{G} be m-linearly presented R-modules, respectively up to order 1 and 2. Let $\mu : \mathbf{E} \rightarrow \mathbf{G}$ be a surjective morphism and consider the induced maps μ^i 's. Then $\mathbf{F} = \ker(\mu)$ is generated in degree m and $m+1$, and moreover:*

- (i) *if μ^1 is surjective, \mathbf{F} is generated in degree m and has linear and quadratic syzygies. Furthermore $\beta_{0,m}(\mathbf{F}) = \beta_{0,m}(\mathbf{E}) - \beta_{0,m}(\mathbf{G})$;*
- (ii) *if moreover μ^2 is surjective, \mathbf{F} is linearly presented and $\beta_{1,m+1}(\mathbf{F}) = \beta_{1,m+1}(\mathbf{E}) - \beta_{1,m+1}(\mathbf{G})$.*

Proof. Set $J^i = \text{im}(e_i)$ and $K^i = \text{im}(g_i)$. The map μ induces an exact commutative diagram:

$$\begin{array}{ccccccccc} 0 & \longrightarrow & J^1 & \longrightarrow & E^0 & \longrightarrow & \mathbf{E} & \longrightarrow & 0 \\ & & \downarrow \nu^1 & & \downarrow \mu^0 & & \downarrow \mu & & \\ 0 & \longrightarrow & K^1 & \longrightarrow & G^0 & \longrightarrow & \mathbf{G} & \longrightarrow & 0 \end{array}$$

Note that $E^0 \rightarrow \mathbf{G}$ is surjective. Hence also μ^0 has to be surjective for otherwise the generators of \mathbf{G} lying in G^0 and not hit by μ^0 would be redundant, contradicting the minimality of $G^0 \rightarrow \mathbf{G}$.

Setting $\alpha_0 = \beta_{0,m}(\mathbf{E})$ and $\gamma_0 = \beta_{0,m}(\mathbf{G})$, we have $E^0 = R(-m)^{\alpha_0}$ and $G^0 = R(-m)^{\gamma_0}$ because \mathbf{E} and \mathbf{G} are *m-linearly presented*. So by the obvious exact sequence

$$0 \longrightarrow \ker(\mu^0) \longrightarrow R(-m)^{\alpha_0} \longrightarrow R(-m)^{\gamma_0} \longrightarrow 0,$$

we deduce $\ker(\mu^0) \simeq R(-m)^{\alpha_0 - \gamma_0}$. Hence, applying snake lemma to the previous diagram, we get:

$$(1.1) \quad 0 \longrightarrow \ker(\nu^1) \longrightarrow R(-m)^{\alpha_0 - \gamma_0} \longrightarrow \mathbf{F} \longrightarrow \text{coker}(\nu^1) \longrightarrow 0.$$

The R -module J^1 is generated in degree $m+1$ and $\text{coker}(\nu^1)$ is a quotient of J^1 , so also $\text{coker}(\nu^1)$ is generated in degree $m+1$. Therefore, by (1.1), we get that \mathbf{F} is generated in degree m and $m+1$, which proves the first statement.

Let us now prove (i). Assume that μ^1 is surjective, and write the exact commutative diagram:

$$\begin{array}{ccccccccc} 0 & \longrightarrow & J^2 & \longrightarrow & E^1 & \longrightarrow & J^1 & \longrightarrow & 0 \\ & & \downarrow \nu^2 & & \downarrow \mu^1 & & \downarrow \nu^1 & & \\ 0 & \longrightarrow & K^2 & \longrightarrow & G^1 & \longrightarrow & K^1 & \longrightarrow & 0 \end{array}$$

Snake lemma this time shows that ν^1 is surjective as well, so that $\text{coker}(\nu^1) = 0$. By (1.1), this says that \mathbf{F} is generated in degree m . Moreover, we obtain $\beta_{0,m}(\mathbf{F}) = \alpha_0 - \gamma_0$, indeed $\ker(\nu^1)$ sits in J^1 , which is minimally generated in degree $m+1$, so $R(-m)^{\alpha_0 - \gamma_0} \rightarrow \mathbf{F}$ is minimal.

Setting $\alpha_1 = \beta_{1,m+1}(\mathbf{E})$ and $\gamma_1 = \beta_{1,m+1}(\mathbf{G})$, as before we get $\ker(\mu^1) \simeq R(-m-1)^{\alpha_1 - \gamma_1}$. Again by snake lemma we obtain the exact sequence:

$$(1.2) \quad 0 \longrightarrow \ker(\nu^2) \longrightarrow R(-m-1)^{\alpha_1 - \gamma_1} \longrightarrow \ker(\nu^1) \longrightarrow \text{coker}(\nu^2) \longrightarrow 0.$$

As before, $\text{coker}(\nu^2)$ is generated in degree $m+2$, so that \mathbf{F} has linear and quadratic syzygies, whereby proving (i).

Finally, to prove (ii), if μ^2 is surjective then $\text{coker}(\nu^2) = 0$, and therefore \mathbf{F} is linearly presented by (1.2). Moreover $\beta_{1,m+1}(\mathbf{F}) = \beta_{1,m+1}(\mathbf{E}) - \beta_{1,m+1}(\mathbf{G})$. Note that the presentation of \mathbf{F} is necessarily minimal in this case. \square

Example 1.1. In this example, we show that the rank of μ^2 depends on the map μ and on the module \mathbf{E} in a rather subtle way, even assuming μ^1 surjective and $\mathbf{G} = \mathbf{k}$, the residual field. It is exactly this subtlety that, in a previous version of this paper, lead us to the false belief that this surjectivity condition, and the subsequent inequality on the Betti numbers of \mathbf{E} and \mathbf{G} , were sufficient for \mathbf{F} to have linear presentation.

Let $n = 2$ and consider positive integers a and b with $b - a \geq 2$. Let \mathbf{E} be defined by a linear matrix A of size $a \times b$ of constant rank $b - a$, so that \mathbf{E} is a linearly presented module of rank $b - a$. The module \mathbf{E} is associated with a Steiner bundle E of rank $b - a$ on \mathbb{P}^2 , see §4.2. Take $\mathbf{G} = \mathbf{k}$. Any non-zero map $\mu : \mathbf{E} \rightarrow \mathbf{k}$ is surjective and is uniquely defined by the choice of a non-zero linear form $\theta : \mathbf{k}^b \rightarrow \mathbf{k}$ representing a linear combination of the rows of A .

The kernel of the obvious Koszul syzygy $R(-1)^3 \rightarrow R$ of \mathbf{k} is the module associated with the sheaf of differential forms $\Omega_{\mathbb{P}^2}$. The map $\mu^1 : R(-1)^a \rightarrow R(-1)^3$ commuting with this syzygy is defined by a scalar matrix $\mathbf{k}^a \rightarrow \mathbf{k}^3$, whose image is nothing but the linear span in \mathbf{k}^3 of the linear forms $\theta A : R(-1)^a \rightarrow \mathbf{k}$. Indeed, the desired map $\mathbf{k}^a \rightarrow \mathbf{k}^3$ is just the $a \times 3$ matrix of the coefficients of θA .

The possible values for the corank v of this map sit between $\max\{0, 3 - a\}$ and 2. Indeed, the map is non-zero (i.e. $v \leq 2$) as otherwise two rows of A would be linearly dependent and E could not be locally free of rank 2. But A may have the same linear form appearing in every entry of the first row, in which case choosing θ as $(1, 0, \dots, 0)$ we get $v = 2$, and so forth. As the value v changes, we get a minimal resolution for $\ker(\mu)$ of the form:

$$0 \longrightarrow R(-3) \longrightarrow R(-2)^3 \oplus R(-1)^{a+v-3} \longrightarrow R(-1)^v \oplus R^{b-1} \longrightarrow \ker(\mu) \longrightarrow 0.$$

In terms of vector bundles, this reads:

$$0 \longrightarrow \Omega_{\mathbb{P}^2} \oplus \mathcal{O}_{\mathbb{P}^2}(-1)^{a+v-3} \longrightarrow \mathcal{O}_{\mathbb{P}^2}(-1)^v \oplus \mathcal{O}_{\mathbb{P}^2}^{b-1} \longrightarrow E \longrightarrow 0.$$

The cokernel of the map ν^2 is R^v , so this is Artinian if and only if $v = 0$. In this case, the linear matrix $R(-1)^{a-3} \rightarrow R^{b-1}$ has constant rank $b - a + 2$.

The previous example does not comply with condition (ii) of Theorem 1.1, so we cannot produce a second linear matrix of constant corank 2. However, the linear part of the presentation matrix of $\ker(\mu)$ still has constant rank. This is explained by our next main result.

Theorem 1.2. *In the assumptions and notations of Theorem 1.1(i), suppose furthermore that:*

- (i) *the sheaves $E = \tilde{\mathbf{E}}$ and $G = \tilde{\mathbf{G}}$ are vector bundles on \mathbb{P}^n of rank r and s respectively;*
- (ii) *the map ν^2 has Artinian cokernel.*

Set $a = \beta_{0,m}(\mathbf{E}) - \beta_{0,m}(\mathbf{G})$ and $b = \beta_{1,m+1}(\mathbf{E}) - \beta_{1,m+1}(\mathbf{G})$. Then the presentation matrix A of $\mathbf{F} = \ker(\mu)$ has a linear part of size $a \times b$ and constant corank $r - s$. Moreover the sheafification $F = \tilde{\mathbf{F}}$ of \mathbf{F} is isomorphic to the kernel of $\tilde{\mu} : E \rightarrow G$.

Proof. The module \mathbf{F} has a minimal generators, all of degree m , by Theorem 1.1. We have also seen that the syzygies of these generators are precisely the module $\ker(\nu^1)$, and that $\text{coker}(\nu^1) = 0$. For $i \geq 0$, set $\alpha_i = \beta_{i,m+i}(\mathbf{E})$ and $\gamma_i = \beta_{i,m+i}(\mathbf{G})$. From the proof of Theorem 1.1, we extract the following commutative diagram:

$$(1.3) \quad \begin{array}{ccccccc} & & 0 & & 0 & & 0 \\ & & \downarrow & & \downarrow & & \downarrow \\ \ker(\nu^2) & \longrightarrow & R(-m-1)^b & \xrightarrow{A} & R(-m)^a & \longrightarrow & \mathbf{F} \longrightarrow 0 \\ \downarrow & & \downarrow & & \downarrow & & \downarrow \\ J^2 & \longrightarrow & R(-m-1)^{\alpha_1} & \longrightarrow & R(-m)^{\alpha_0} & \longrightarrow & \mathbf{E} \longrightarrow 0 \\ \downarrow \nu^2 & & \downarrow \mu^1 & & \downarrow \mu^0 & & \downarrow \mu \\ K^2 & \longrightarrow & R(-m-1)^{\gamma_1} & \longrightarrow & R(-m)^{\gamma_0} & \longrightarrow & \mathbf{G} \longrightarrow 0 \\ \downarrow & & \downarrow & & \downarrow & & \downarrow \\ \text{coker}(\nu^2) & & 0 & & 0 & & 0 \end{array}$$

Here, exactness of the diagram takes place everywhere except on the first line, where the kernel of the surjective map $R(-m)^a \rightarrow \mathbf{F}$ is the module $\ker(\nu^1)$ which fits into the exact sequence (1.2). Equivalently, $\text{coker}(\nu^2)$ is the middle homology of the complex:

$$(1.4) \quad 0 \rightarrow \ker(\nu^2) \rightarrow R(-1-m)^b \rightarrow R(-m)^a \rightarrow \mathbf{F} \rightarrow 0.$$

Recall that $\text{coker}(\nu^2)$ has generators of degree $m+2$, so the linear part of the presentation of \mathbf{F} is the $a \times b$ matrix A appearing in the diagram. Note that this holds independently of E being locally free.

Now since $\text{coker}(\nu^2)$ is Artinian, specializing (1.4) and (1.3) to any closed point of \mathbb{P}^n we see that the matrix A presents $F = \ker(\tilde{\mu})$ as a coherent sheaf over \mathbb{P}^n . The fact that A has constant corank $r - s$ follows. Indeed, the sheaves E and G are locally free and the induced map $\tilde{\mu} : E \rightarrow G$ is surjective, so also $F = \ker(\tilde{\mu})$ is locally free, clearly of rank $r - s$. Also, since A presents \mathbf{F} modulo the Artinian module $\text{coker}(\nu^2)$, we have $F \simeq \tilde{\mathbf{F}}$, a locally free sheaf of rank $r - s$. In other words, A has constant corank $r - s$. \square

Remark 1.1. We will mostly use this theorem in the case $G = 0$, i.e. when \mathbf{G} is also Artinian. Of course, a way to guarantee that ν^2 has Artinian cokernel is to assume that μ^2 is surjective as in Theorem 1.1.

2. COMPARISON WITH OTHER STRATEGIES

As suggested in the introduction, the idea of using vector bundles to study and then explicitly construct linear matrices of constant rank dates back to the 80's. Indeed an $n+1$ -dimensional linear space of $a \times b$ matrices of constant rank ρ gives rise to an exact sequence of vector bundles on \mathbb{P}^n :

$$(2.1) \quad 0 \longrightarrow K \longrightarrow \mathcal{O}_{\mathbb{P}^n}(-1)^b \xrightarrow{A} \mathcal{O}_{\mathbb{P}^n}^a \longrightarrow E \longrightarrow 0,$$

where $K = \ker A$ has rank $r = b - \rho$ and $E = \text{coker } A$ has rank $s = a - \rho$.

It is well known that the smaller the difference $n - r$ is, the easier it becomes to find indecomposable (nontrivial) rank r bundles on \mathbb{P}^n , see for example [OSS80, Chapter 4]. As a consequence, one has more hopes to construct examples of the type we are after by first building a bigger matrix of size $\alpha \times \beta$ and constant rank ρ , and then projecting it to a smaller $a \times b$ matrix of the same rank ρ . Cutting down columns (respectively rows) is equivalent to taking a quotient of the rank $\beta - \rho$ bundle K (resp. the rank $\alpha - \rho$ bundle E), as shown in the following commutative diagram (or in an equivalent one for cutting down rows):

$$\begin{array}{ccccccc}
& & 0 & & 0 & & \\
& & \downarrow & & \downarrow & & \\
& & \mathcal{O}_{\mathbb{P}^n}^{b-\beta}(-1) = \mathcal{O}_{\mathbb{P}^n}^{b-\beta}(-1) & & & & \\
& & \downarrow & & \downarrow & & \\
0 & \longrightarrow & K & \longrightarrow & \mathcal{O}_{\mathbb{P}^n}^b(-1) & \xrightarrow{A} & \mathcal{O}_{\mathbb{P}^n}^a \longrightarrow E \longrightarrow 0 \\
& & \downarrow & & \downarrow & & \parallel \\
0 & \longrightarrow & Q & \longrightarrow & \mathcal{O}_{\mathbb{P}^n}^\beta(-1) & \xrightarrow{A'} & \mathcal{O}_{\mathbb{P}^n}^\alpha \longrightarrow \text{coker}(A') \longrightarrow 0 \\
& & \downarrow & & \downarrow & & \\
& & 0 & & 0 & &
\end{array}$$

This technique was used for example in [FM11, BM15]. So what is the advantage of our method over that of projecting bigger matrices? The following Proposition answers the question.

Proposition 2.1. *Let A be a linear space of $a \times b$ matrices of constant rank ρ , and $\dim(A) = n + 1$. A induces by projection a space A' of $\alpha \times \beta$ matrices of the same constant rank ρ and dimension $n + 1$ for any $\alpha \geq \rho + n$ and $\beta \geq \rho + n$.*

Proposition 2.1 generalizes a similar result for skew-symmetric matrices appearing in [FM11]. An immediate consequence is that $n + 1$ -dimensional spaces of matrices of constant rank cannot be constructed via projection as soon as n is bigger than $\min\{\alpha - \rho, \beta - \rho\}$; on the contrary, our method works for many such cases, as shown in the next sections. We will call the examples where $n > \min\{\alpha - \rho, \beta - \rho\}$ of *small corank*.

Proof. We will prove the result working on the number of columns; the other proof is identical. The space $\mathbb{P}A$ lies in the stratum

$$\sigma_\rho(\text{Seg}(\mathbb{P}^{a-1} \times \mathbb{P}^{b-1})) \setminus \sigma_{\rho-1}(\text{Seg}(\mathbb{P}^{a-1} \times \mathbb{P}^{b-1})) \hookrightarrow \mathbb{P}(\mathbf{k}^a \otimes \mathbf{k}^b)$$

of the ρ th secant variety to the Segre variety $\text{Seg}(\mathbb{P}^{a-1} \times \mathbb{P}^{b-1})$ minus its singular locus. We prove that $\mathbb{P}A$ can be isomorphically projected to $\sigma_\rho(\text{Seg}(\mathbb{P}^{a-1} \times \mathbb{P}^{n+\rho}))$.

Taking a quotient Q of the bundle K as above corresponds to projecting \mathbb{P}^{b-1} onto $\mathbb{P}^{\beta-1}$ from the span of $b - \beta$ independent points $O := \langle x_1, \dots, x_{b-\beta} \rangle$; let us call this projection π_O . This in turn induces a projection $\pi_{S_O} : \mathbb{P}(\mathbf{k}^a \otimes \mathbf{k}^b) \rightarrow \mathbb{P}(\mathbf{k}^\alpha \otimes \mathbf{k}^\beta)$, whose center S_O is the image of $\mathbb{P}^{a-1} \times O$ in $\mathbb{P}(\mathbf{k}^a \otimes \mathbf{k}^b)$ through the Segre embedding.

Now let $\omega \in \mathbb{P}A$ be any point; then $\omega = [v_1 \otimes w_1 + \dots + v_\rho \otimes w_\rho]$ where $v_i \otimes w_i$ are independent, and in particular w_1, \dots, w_ρ are independent vectors in \mathbf{k}^b . Thus they generate a subspace L_ω in \mathbb{P}^{b-1} of dimension $\rho - 1$.

Claim. Given $O \subset \mathbb{P}^{b-1}$ such that $\mathbb{P}A \cap S_O = \emptyset$, the matrices $\pi_{S_O}(\mathbb{P}A)$ have constant rank ρ if and only if O does not intersect the union of the spaces L_ω , as ω varies in $\mathbb{P}A$.

To prove the claim, notice that $\pi_{S_O}(\mathbb{P}A)(\omega) = [v_1 \otimes M w_1 + \dots + v_\rho \otimes M w_\rho]$, where M is the matrix representing π_O . But then its rank is strictly less than ρ if and only if the w_i 's can be chosen in a way that some summand $v_i \otimes M w_i$ vanish. On the other hand, the entry locus of ω is exactly

the Segre variety $\text{Seg}(\mathbb{P}^{a-1} \times L_\omega) \hookrightarrow \text{Seg}(\mathbb{P}^{a-1} \times \mathbb{P}^{b-1})$. So a point of $\text{Seg}(\mathbb{P}^{a-1} \times \mathbb{P}^{b-1})$ belongs to some ρ -secant plane to the Segre, and containing ω , if and only if it belongs to $\text{Seg}(\mathbb{P}^{a-1} \times L_\omega)$.

In other words the existence of a choice of w_1, \dots, w_ρ such that some $v_i \otimes Mw_i$ vanish is equivalent to saying that O intersects L_ω . This proves the claim.

To finish the proof of Proposition 2.1, just notice that:

$$\dim \bigcup_{\omega \in \mathbb{P}^A} L_\omega \leq \dim(\mathbb{P}^A) + \dim(L_\omega) = n + \rho - 1. \quad \square$$

Other than via the projection method that we have just described, all known examples—to the best of our knowledge—of spaces of matrices of constant rank are obtained through cumbersome explicit constructions, that only work case by case.

Apart from being interesting in their own right, such examples can be used to determine effective lower bounds for the maximal dimension of spaces of matrices. Indeed the question of determining the value of $l(a, b, r)$, the maximal dimension of a subspace of $a \times b$ matrices of rank r , is still wide open. Among these types of “ad hoc” constructions, let us at least quote [Wes90], where the author finds the effective value of $l(r+1, r+n-1, r)$ (in the case when n divides r) exactly by providing explicit examples of $n+1$ -dimensional spaces of matrices of the prescribed size and rank.

A little more in detail, from a computation of invariants of vector bundles [Wes87] it follows that for any integers $2 \leq r \leq a \leq b$ one has:

$$b - r + 1 \leq l(a, b, r) \leq a + b - 2r + 1,$$

and moreover $l(a, b, r) = b - r + 1$ whenever $b - r + 1$ does not divide $(a-1)!/(r-1)!$. In particular, then the value $l(r+1, r+n-1, r)$ can be either n or $n+1$. To achieve this explicit construction, fix $n+1$ independent variables x_0, \dots, x_n and define the matrix $(kn+1) \times (kn+n-1)$ matrix $H_{n,k} = (h_{ij})$ as:

$$h_{i,j} = \begin{cases} x_{j-i+1}, & \text{if } 0 \leq j-i+1 \leq n \text{ and } j \not\equiv 0 \pmod{k+1}, \\ (a-j+i-1)x_{j-i+1}, & \text{if } 0 \leq j-i+1 \leq n \text{ and } j \equiv a \pmod{k+1}, \\ 0, & \text{otherwise.} \end{cases}$$

It is not too hard to see that the rank of $H_{n,k}$ is at least kn ; by constructing an appropriate annihilator for $H_{n,k}$ one is then able to conclude that the rank is indeed kn . The construction of the annihilator is as ingenious as it is long and complicated; on the contrary, as anticipated in the introduction, our method give such matrices in a very direct way; in section 4.1 we wrote out an explicit example where our algorithm applied to a line bundle on \mathbb{P}^2 gives precisely the matrices described above.

3. A CLOSER LOOK AT THE MODULES \mathbf{E} AND \mathbf{G}

Keeping in mind our goal of constructing explicit examples of constant rank matrices, we now want to investigate some features modules satisfying Theorem 1.1's and Theorem 1.2's hypotheses. In particular, we seek numerical ranges for Betti numbers $\beta_{0,m}$ and $\beta_{1,m+1}$ of modules \mathbf{E} and \mathbf{G} . Once one determines two modules \mathbf{E} and \mathbf{G} that numerically provide the desired size of the presentation matrix of the module \mathbf{F} , one can look explicitly for a surjective morphism μ .

3.1. The module \mathbf{E} . As $E = \tilde{E}$ is expected to be a vector bundle of rank r , we consider the module $H_*^0(E) = \bigoplus_t H^0(E(t))$ of global sections of a vector bundle E of rank r . In general, such a module will not be linearly presented. Nevertheless, we are free to consider any truncation $H_*^0(E)_{\geq m}$ in such a way that it is linearly presented. By Theorem 1.2, the presentation matrix will indeed have corank r .

In what follows it will be useful to know the Betti numbers of all truncations of a module (without needing to determine them explicitly).

Lemma 3.1. *Let \mathbf{M} be a finitely generated graded R -module and let $m \geq \text{reg}(\mathbf{M})$ be an integer number. The truncated module $\mathbf{M}_{\geq m}$ is m -regular, and assume that it has linear resolution:*

$$0 \rightarrow R(-m-n)^{\beta_{n,m+n}} \rightarrow \dots \rightarrow R(-m-i)^{\beta_{i,m+i}} \rightarrow \dots \rightarrow R(-m)^{\beta_{0,m}} \rightarrow \mathbf{M}_{\geq m} \rightarrow 0.$$

Then the truncated module $\mathbf{M}_{\geq m+k}$, with $k \geq 1$, has regularity $m+k$ and linear resolution:

$$0 \rightarrow R(-m-k-n)^{\beta_{n,m+n+k}} \rightarrow \dots \rightarrow R(-m-k)^{\beta_{0,m+k}} \rightarrow \mathbf{M}_{\geq m+k} \rightarrow 0$$

with

$$\beta_{i,m+i+k} = a_k^{(i)} \beta_{0,m} - a_{k-1}^{(i)} \beta_{1,m+1} + \dots + (-1)^n a_{k-n}^{(i)} \beta_{n,m+n} = \sum_{j=0}^n (-1)^j a_{k-j}^{(i)} \beta_{j,m+j},$$

where for all $i = 0, \dots, n$, the sequence $(a_k^{(i)})$ belongs to the set of recursive sequences:

$$\text{RS}_n := \left\{ (a_k) \mid a_{k+1} = \sum_{j=0}^n (-1)^j \binom{n+1}{j+1} a_{k-j} \right\}.$$

More in detail, $(a_k^{(i)})$ is defined by the initial values:

$$(3.1) \quad a_1^{(i)} = \binom{n+1}{i+1}, \quad a_{-i}^{(i)} = (-1)^i \quad \text{and} \quad a_{-j}^{(i)} = 0 \text{ for } j \neq -1, i \text{ and } j < n.$$

Proof. The exact sequence $0 \rightarrow \mathbf{M}_{\geq m+k+1} \rightarrow \mathbf{M}_{\geq m+k} \rightarrow \mathbf{M}_{m+k} \rightarrow 0$ induces the long exact sequence (see [Pee11, Theorem 38.3]):

$$(3.2) \quad \begin{array}{ccccccc} \dots & \longrightarrow & \text{Tor}_2(\mathbf{M}_{\geq m+k}, \mathbf{k}) & \longrightarrow & \text{Tor}_2(\mathbf{M}_{m+k}, \mathbf{k}) & \longrightarrow & \dots \\ & & \longleftarrow & & \longleftarrow & & \\ & & \text{Tor}_1(\mathbf{M}_{\geq m+k+1}, \mathbf{k}) & \longrightarrow & \text{Tor}_1(\mathbf{M}_{\geq m+k}, \mathbf{k}) & \longrightarrow & \text{Tor}_1(\mathbf{M}_{m+k}, \mathbf{k}) \\ & & \longleftarrow & & \longleftarrow & & \\ & & \text{Tor}_0(\mathbf{M}_{\geq m+k+1}, \mathbf{k}) & \longrightarrow & \text{Tor}_0(\mathbf{M}_{\geq m+k}, \mathbf{k}) & \longrightarrow & \text{Tor}_0(\mathbf{M}_{m+k}, \mathbf{k}) \longrightarrow 0 \end{array}$$

where the modules $\text{Tor}_i(\bullet, \mathbf{k})$ are graded of finite length and the dimensions of the homogeneous pieces are equal to the Betti numbers of the minimal free resolutions of the modules [Pee11, Theorem 11.2]. Hence, one determines the relation between Betti numbers of consecutive truncations working recursively with this sequence, keeping in mind that the modules $\mathbf{M}_{\geq m+k}$ and \mathbf{M}_{m+k} have $(m+k)$ -linear resolution while $\mathbf{M}_{\geq m+k+1}$ has $(m+k+1)$ -linear resolution. \square

By induction on n one can also prove the following Lemma.

Lemma 3.2. *Any recursive sequence $(a_k) \in \text{RS}_n$ has a degree n polynomial as its generating function. In particular, the generating function of the sequence $(a_k^{(i)})$ defined in (3.1) is the following:*

$$p_n^{(i)}(k) = \binom{n}{i} \binom{k+n-1}{n} \frac{k+n}{k+i}.$$

Remark that in the case $i = 0$ one gets that $p_n^{(0)}(k) = \binom{k+n}{n}$.

Example 3.1. Consider the polynomial ring $R = \mathbf{k}[x_0, x_1, x_2]$. As module over itself, R is 0-regular with resolution $0 \rightarrow R \rightarrow R \rightarrow 0$ ($\beta_{0,0} = 1$, $\beta_{1,1} = 0$, $\beta_{2,2} = 0$). By Lemma 3.1 and 3.2, the resolution of $R_{\geq k}$ for every $k \geq 0$ is

$$0 \rightarrow R(-k-2)^{\beta_{2,k+2}} \rightarrow R(-k-1)^{\beta_{1,k+1}} \rightarrow R(-k)^{\beta_{0,k}} \rightarrow R_{\geq k} \rightarrow 0,$$

where

$$(3.3) \quad \begin{aligned} \beta_{0,k} &= a_k^{(0)}\beta_{0,0} - a_{k-1}^{(0)}\beta_{1,1} + a_{k-2}^{(0)}\beta_{2,2} = p_2^{(0)}(k) = \binom{k+2}{2} = \frac{1}{2}(k^2 + 3k + 2), \\ \beta_{1,k+1} &= a_k^{(1)}\beta_{0,0} - a_{k-1}^{(1)}\beta_{1,1} + a_{k-2}^{(1)}\beta_{2,2} = p_2^{(1)}(k) = \binom{2}{1} \binom{k+1}{2} \frac{k+2}{k+1} = k^2 + 2k, \\ \beta_{2,k+2} &= a_k^{(2)}\beta_{0,0} - a_{k-1}^{(2)}\beta_{1,1} + a_{k-2}^{(2)}\beta_{2,2} = p_2^{(2)}(k) = \binom{2}{2} \binom{k+1}{2} \frac{k+2}{k+2} = \frac{1}{2}(k^2 + k). \end{aligned}$$

Therefore, we can predict the resolution of $R_{\geq 10}$:

$$0 \rightarrow R(-12)^{55} \rightarrow R(-11)^{120} \rightarrow R(-10)^{66} \rightarrow R_{\geq 10} \rightarrow 0.$$

3.2. The module \mathbf{G} . As we pointed out at the end of Section 1, we will often consider Artinian modules for the module \mathbf{G} , so that the corank of the presentation matrices of \mathbf{E} and \mathbf{F} is the same. Another advantage of using Artinian modules is that we can exploit many results from Boij-Söderberg theory about the Betti numbers of a module with given degrees of the maps in the complex, as well as explicit methods for the construction of such modules [ESS].

We recall some basic results about Artinian modules with pure resolution. We can use them as building blocks for general Artinian modules. The resolution of an Artinian module \mathbf{G} is called *pure* with degree sequence (d_0, \dots, d_{n+1}) , $d_0 < \dots < d_{n+1}$ if it has the shape:

$$0 \rightarrow R(-d_{n+1})^{\beta_{n+1,d_{n+1}}} \rightarrow \dots \rightarrow R(-d_1)^{\beta_{1,d_1}} \rightarrow R(-d_0)^{\beta_{0,d_0}} \rightarrow \mathbf{G} \rightarrow 0.$$

It has been proved that such a module exists (see [BS08, EFW11, ES09] for details) and that its Betti numbers solve the so-called *Herzog-Kühl equations*:

$$\beta_{i,d_i} = q \prod_{\substack{j=0 \\ j \neq i}}^{n+1} \frac{1}{|d_j - d_i|}, \quad i = 0, \dots, n+1, \quad \text{for some } q \in \mathbb{Q}.$$

Since we are interested in modules with linear presentation up to order 2, we may assume $d_0 = 0$, $d_1 = 1$ and $d_2 = 2$. In this case, the first three Betti numbers turn out to be

$$(3.4) \quad \beta_{0,0} = \frac{q}{2d_3 \cdots d_{n+1}}, \quad \beta_{1,1} = \frac{q}{(d_3 - 1) \cdots (d_{n+1} - 1)}, \quad \beta_{2,2} = \frac{q}{2(d_3 - 2) \cdots (d_{n+1} - 2)},$$

where q is a multiple of:

$$\left(\prod_{2 < i < j < n+1} |d_i - d_j| \right) \cdot \text{LCM}\{d_i, d_i - 1, d_i - 2 \mid i = 3, \dots, n+1\}.$$

4. CONSTRUCTION OF SPECIAL LINEAR PRESENTATION OF VECTOR BUNDLES

Let us spell out clearly our strategy to construct linear matrices of constant rank. Suppose that, for a given triple of integers (ρ, a, b) with $\rho < \min\{a, b\}$, we want to construct an $a \times b$ matrix of linear forms of constant rank ρ in the polynomial ring with $n+1$ variables. Then we have to search for an $a \times b$ matrix of linear forms presenting a vector bundle E of rank $r = a - \rho$ on \mathbb{P}^n . In general, if E is a vector bundle of rank r , its module of global sections \mathbf{E} will not be linearly presented. Nevertheless, we are free to truncate \mathbf{E} in such a way that it is linearly presented. By Theorem 1.2, the presentation matrix will indeed have corank r . However, it is unlikely that its size equals $a \times b$. Here is where Theorem 1.1 and Theorem 1.2 come into play, as we may remove a 2-linearly presented Artinian module from our truncation of \mathbf{E} in order to reduce the size of our presentation matrix, and hopefully arrive at size $a \times b$.

Note that, given E , there are infinitely many truncations of $\mathbf{E} = H_*^0(E)$. For each truncation $\mathbf{E}_{\geq k}$ (1) one can look at the finitely many Artinian modules with pure resolution and Betti numbers compatible with the assumptions of Theorem 1.1, and (2) one needs to look for a surjective

homomorphism μ inducing a surjective map μ^1 and a map ν^2 with Artinian cokernel. Moreover, we can repeat the same procedure for each module with linear presentation obtained in this way, and so on.

We illustrate these possibilities with a tree structure:

- the nodes of the tree are graded modules and, in particular, the root of the tree is the truncation $\mathbf{E}_{\geq k}$ for some k of the module $\mathbf{E} = H_*^0(E)$ of global sections of a vector bundle E ;
- for each node corresponding to a linearly presented module \mathbf{F} , the edges are the possible Artinian modules \mathbf{G} with pure resolution and Betti numbers numerically compatible with the Betti numbers of \mathbf{F} in relation with the assumptions of Theorems 1.1 and 1.2 and the children are the kernels of a generic morphism $\mu : \mathbf{F} \rightarrow \mathbf{G}$;
- if the module corresponding to a node is not linearly presented or there does not exist an Artinian module with pure resolution and compatible Betti numbers, the node is a leaf of the tree.

The reduction process represented by a sequence of edges can be thought as equivalent to a single step of reduction done using the module \mathbf{G} obtained as direct sum of the modules corresponding to the edges in the sequence. Thus, we simplify the tree do not allowing paths corresponding to permutations of the edges and paths with multiple edges corresponding to resolutions with the same degree sequence. An explicit example of such a tree can be found in Figure 1.

4.1. Line bundles. To give a first application of Theorem 1.2, we show how to produce a subspace of dimension 3 of the space of $(2s + 1) \times (2s + 1)$ matrices of constant rank $2s$. Such spaces are an example of those determined by Westwick in [Wes90] that we illustrated in section 2.

We consider as \mathbf{E} the module of section of a line bundle $\mathcal{O}_{\mathbb{P}^2}(l)$ over \mathbb{P}^2 . The resolution of the general truncation $\mathbf{E}_{\geq k}$ was described in Example 3.1. As for \mathbf{G} , we consider pure Artinian modules with degree sequence $(k, k + 1, k + 2, k + d)$; in this case, the general solution of the Herzog-Kühl equations is

$$\beta_{0,k}(\mathbf{G}) = q \frac{d^2 - 3d + 2}{2}, \quad \beta_{1,k}(\mathbf{G}) = q(d^2 - 2d), \quad \beta_{2,k}(\mathbf{G}) = q \frac{d^2 - d}{2}, \quad \beta_{3,k}(\mathbf{G}) = q.$$

Hence, we look for positive integers k, d, q such that

$$\begin{aligned} \beta_{0,k}(\mathbf{E}_{\geq k}) - \beta_{0,k}(\mathbf{G}) &= \frac{k^2 + 3k + 2}{2} - q \frac{d^2 - 3d + 2}{2} = 2s + 1, \\ \beta_{1,k}(\mathbf{E}_{\geq k}) - \beta_{1,k}(\mathbf{G}) &= k^2 + 2k - q(d^2 - 2d) = 2s + 1. \end{aligned}$$

It is easy to show that for every s , we have the solution $k = s$, $d = s + 1$ and $q = 1$, and a module with such resolution always exists (see for instance [ES09, Theorem 5.1]). Finally, one has to determine a morphism $\mu : \mathbf{E}_{\geq k} \rightarrow \mathbf{G}$ satisfying the assumption of Theorem 1.2. Figure 2 shows what happens in the case $s = 2$. Then, the morphism $\mu : \mathbf{E}_{\geq 2} \rightarrow \mathbf{G}$ defined by the map between the generators $R(-2)^6 \xrightarrow{[0 \ 0 \ -1 \ 1 \ 0 \ 0]} R(-2)$ satisfies the hypothesis of Theorems 1.1 and 1.2 so that the presentation of $\ker \mu$ is a 5×5 matrix of constant rank 4 that looks exactly like the matrix $H_{2,2}$ defined in [Wes90]:

$$\begin{bmatrix} -x_1 & -x_2 & 0 & 0 & 0 \\ x_0 & -x_1 & -x_2 & 0 & 0 \\ 0 & x_0 & 0 & -x_2 & 0 \\ 0 & 0 & x_0 & x_1 & -x_2 \\ 0 & 0 & 0 & x_0 & x_1 \end{bmatrix}.$$

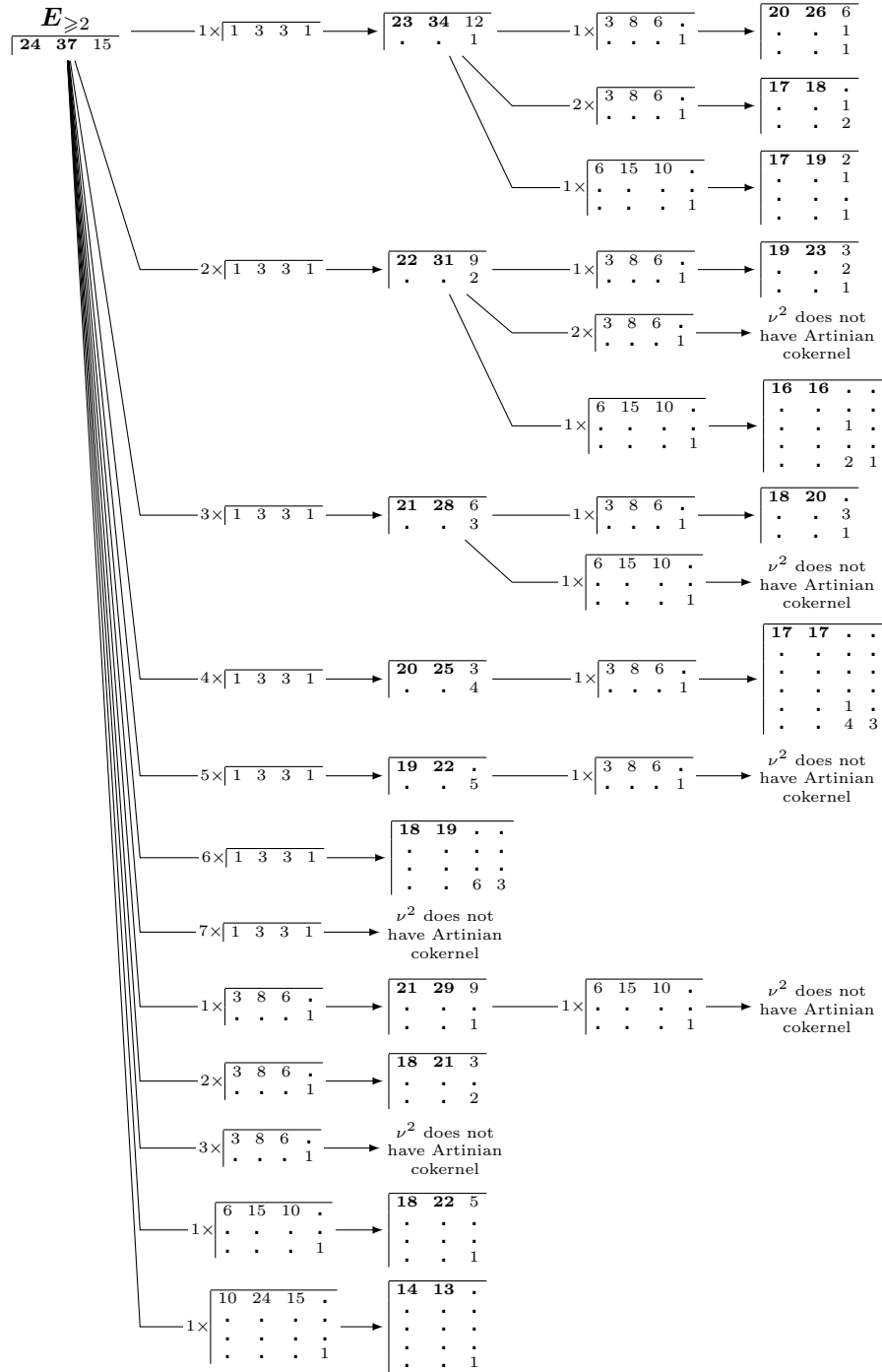

FIGURE 1. The set of constant rank matrices that can be produced with our method applied to the truncation $E_{\geq 2} = \oplus_{t \geq 2} H^0(\mathbb{P}^2(t-1))$ the module of global sections of a twist of the tangent bundle $E = \mathbb{T}_{\mathbb{P}^2}(-1)$.

$$\begin{array}{ccc}
R(-4)^3 & \xrightarrow{\begin{bmatrix} \mu_3 & \mu_4 & \mu_5 \\ -\mu_1 & -\mu_2 & -\mu_4 \\ \mu_0 & \mu_1 & \mu_3 \end{bmatrix}} & R(-4)^3 \\
\downarrow \begin{bmatrix} x_2 & 0 & 0 \\ 0 & x_2 & 0 \\ -x_1 & 0 & 0 \\ x_0 & 0 & -x_2 \\ 0 & -x_1 & x_2 \\ 0 & x_0 & 0 \\ 0 & 0 & -x_1 \\ 0 & 0 & x_0 \end{bmatrix} & & \downarrow \begin{bmatrix} -x_1 & -x_2 & 0 \\ x_0 & 0 & -x_2 \\ 0 & x_0 & x_1 \end{bmatrix} \\
R(-3)^8 & \xrightarrow{\begin{bmatrix} \mu_1 & \mu_2 & \mu_3 & 0 & \mu_4 & 0 & \mu_5 & 0 \\ -\mu_0 & -\mu_1 & 0 & \mu_3 & 0 & \mu_4 & 0 & \mu_5 \\ 0 & 0 & -\mu_0 & -\mu_1 & -\mu_1 & -\mu_2 & -\mu_3 & -\mu_4 \end{bmatrix}} & R(-3)^3 \\
\downarrow \begin{bmatrix} -x_1 & 0 & -x_2 & 0 & 0 & 0 & 0 & 0 \\ x_0 & -x_1 & 0 & -x_2 & -x_2 & 0 & 0 & 0 \\ 0 & x_0 & 0 & 0 & 0 & -x_2 & 0 & 0 \\ 0 & 0 & x_0 & x_1 & 0 & 0 & -x_2 & 0 \\ 0 & 0 & 0 & 0 & x_0 & x_1 & 0 & -x_2 \\ 0 & 0 & 0 & 0 & 0 & 0 & x_0 & x_1 \end{bmatrix} & & \downarrow [x_0 \ x_1 \ x_2] \\
R(-2)^6 & \xrightarrow{[\mu_0 \ \mu_1 \ \mu_2 \ \mu_3 \ \mu_4 \ \mu_5]} & R(-2) \\
\downarrow [x_0^2 \ x_0x_1 \ x_1^2 \ x_0x_2 \ x_1x_2 \ x_2^2] & & \downarrow \\
\mathbf{E}_{\geq 2} & \xrightarrow{\mu} & \mathbf{G} \\
\downarrow & & \downarrow \\
0 & & 0
\end{array}$$

FIGURE 2. Description of the general morphism μ between the module $\mathbf{E}_{\geq 2}$, where $\mathbf{E} = R = \mathbf{k}[x_0, x_1, x_2]$, and $\mathbf{G} = \mathbf{k}(-2)$. Any non-zero morphism μ is surjective. If $\mu^{-1}(1) = \langle x_i^2 \rangle$ for some i , the morphisms μ^1 and μ^2 are not surjective and the presentation of $\ker \mu$ is $R(-4)^2 \oplus R(-3)^6 \rightarrow R(-3) \oplus R(-2)^5$. If $\mu^{-1}(1) = \langle x_i x_j \rangle$, $i \neq j$, then μ^1 is surjective but μ^2 is not, and the presentation turns out to be $R(-4) \oplus R(-3)^5 \rightarrow R(-2)^5 \rightarrow \ker \mu$. Finally, for a generic morphism μ , both μ^1 and μ^2 are surjective and $\ker \mu$ is linearly presented ($R(-3)^5 \rightarrow R(-2)^5$).

4.2. Steiner bundles, linear resolutions and generalizations. In “classical” literature a vector bundle E on \mathbb{P}^n having a linear resolution of the form:

$$0 \rightarrow \mathcal{O}_{\mathbb{P}^n}(-1)^s \rightarrow \mathcal{O}_{\mathbb{P}^n}^{s+r} \rightarrow E \rightarrow 0,$$

with $s \geq 1$ and $r \geq n$ integers, is called a (rank r) *Steiner bundle*. This motivates the following definition.

Definition 4.1. Let $r \geq n$ and $s \geq 1$ be integer numbers. The cokernel $E_{s,r}^{(m)}$ of a generic morphism:

$$\mathcal{O}_{\mathbb{P}^n}(-m-1)^s \xrightarrow{\phi} \mathcal{O}_{\mathbb{P}^n}^{s+r}$$

is a vector bundle on \mathbb{P}^n , that we call *generalized Steiner bundle*.

Classical Steiner bundles are of the form $E_{s,r}^{(0)}$. Given a generalized Steiner bundle, the graded module $\mathbf{E}^{(m)} := \mathbf{H}_*^0(E_{s,r}^{(m)})$ has the following resolution:

$$(4.1) \quad 0 \rightarrow R(-m-1)^s \rightarrow R^{s+r} \rightarrow \mathbf{E}^{(m)} \rightarrow 0,$$

and its regularity is exactly equal to m . Remark though that the module $\mathbf{E}^{(m)}$ does not fit the bill for our purposes: first of all for $m \neq 0$ its resolution is not linear, and even in the case $m = 0$ one has $\mathrm{Tor}_2(\mathbf{E}^{(0)}, \mathbf{k})_2 = 0$. For this reason we need to truncate it in higher degree, as explained in the following lemma.

Lemma 4.1. *Let $E_{s,r}^{(m)}$ be a rank r generalized Steiner bundles, with graded modules of sections $\mathbf{E}^{(m)} = \mathbb{H}_*^0(E_{s,r}^{(m)})$. The linear resolution of the truncation $\mathbf{E}_{\geq m}^{(m)}$ is of the form:*

$$0 \rightarrow \cdots \rightarrow R(-m-i)^{\alpha_{i,m}^{(m)}} \rightarrow \cdots \rightarrow R(-m)^{\alpha_{0,m}^{(m)}} \rightarrow \mathbf{E}_{\geq m}^{(m)} \rightarrow 0$$

where:

$$(4.2) \quad \alpha_{i,m}^{(m)} = p_n^{(i)}(m)(s+r) - p_n^{(i)}(-1)s.$$

Proof. Looking at the homogeneous piece of degree $m+i$ of the resolution of $\mathbf{E}_{\geq m}^{(m)}$:

$$0 \rightarrow \cdots \rightarrow R(-m-i)_{m+i}^{\alpha_{i,m}^{(m)}} \rightarrow \cdots \rightarrow R(-m)_{m+i}^{\alpha_{0,m}^{(m)}} \rightarrow (\mathbf{E}_{\geq m}^{(m)})_{m+i} \rightarrow 0,$$

we deduce that:

$$\alpha_{i,m}^{(m)} = \sum_{j=1}^i (-1)^{j-1} \binom{n+j}{n} \alpha_{i-j,m}^{(m)} + (-1)^i \dim_{\mathbf{k}} (\mathbf{E}_{\geq m}^{(m)})_{m+i}.$$

Since $(\mathbf{E}_{\geq m}^{(m)})_{m+i} = (\mathbf{E}^{(m)})_{m+i}$, for all $i \geq 0$, we compute the dimension of the homogeneous piece of degree $m+i$ of $\mathbf{E}_{\geq m}^{(m)}$ from the simpler resolution (4.1):

$$\dim_{\mathbf{k}} (\mathbf{E}_{\geq m}^{(m)})_{m+i} = \dim_{\mathbf{k}} (\mathbf{E}^{(m)})_{m+i} = \binom{n+m+i}{n} (s+r) - \binom{n+i-1}{n} s.$$

We now proceed by induction on i ; for $i = 0$, we have:

$$\alpha_{0,m}^{(m)} = \dim_{\mathbf{k}} (\mathbf{E}_{\geq m}^{(m)})_m = \binom{n+m}{n} (s+r) - \binom{n-1}{n} s = p_n^{(0)}(m)(s+r) - p_n^{(0)}(-1)s.$$

By inductive hypothesis, (4.2) holds for $0, \dots, i-1$. We get:

$$\begin{aligned} \alpha_{i,m}^{(m)} &= \sum_{j=1}^i (-1)^{j-1} \binom{n+j}{n} \left(p_n^{(i-j)}(m)(s+r) - p_n^{(i-j)}(-1)s \right) + \\ &\quad (-1)^i \left(\binom{n+m+i}{n} (s+r) - \binom{n+i-1}{n} s \right) = \\ &= \left[\sum_{j=1}^i (-1)^{j-1} \binom{n+j}{n} p_n^{(i-j)}(m) + (-1)^i \binom{n+m+i}{n} \right] (s+r) - \\ &\quad \left[\sum_{j=1}^i (-1)^{j-1} \binom{n+j}{n} p_n^{(i-j)}(-1) + (-1)^i \binom{n+i-1}{n} \right] s. \end{aligned}$$

The result follows from the observation that the univariate polynomial $p_n^{(i)}(k)$ coincides with:

$$\sum_{j=1}^i (-1)^{j-1} \binom{n+j}{n} p_n^{(i-j)}(k) + (-1)^i \binom{n+k+i}{n},$$

because both polynomials have degree n and take the same value at $k = 0, -1, \dots, -n$. \square

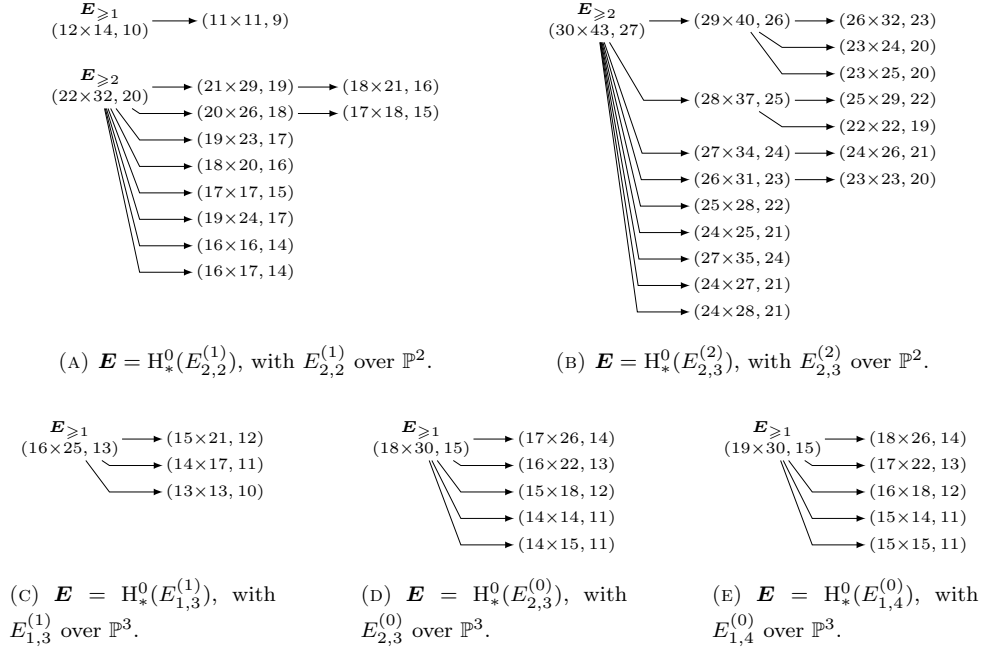

FIGURE 3. Examples of possible constant rank matrices arising from generalized Steiner bundles. The triple $(a \times b, \rho)$ indicates an $a \times b$ matrix of constant rank ρ .

4.3. Linear monads and instanton bundles. Mathematical instanton bundles were first introduced in [OS86] as rank $2m$ bundles on \mathbb{P}^{2m+1} satisfying certain cohomological conditions. They generalize particular rank 2 bundles on \mathbb{P}^3 whose study was motivated by problems from physics, see [AHD78]. They can also be defined as cohomology of a linear monad; in our work we consider an even more general definition, in the spirit of [Jar06]. First, recall that a *monad* (on \mathbb{P}^n) is a complex:

$$A \xrightarrow{f} B \xrightarrow{g} C$$

of vector bundles over \mathbb{P}^n which is exact everywhere but in the middle, and such that $\text{im } f$ is a subbundle of B . Its cohomology is the vector bundle $E = \ker g / \text{im } f$.

Definition 4.2. A *generalized instanton bundle* is a rank r vector bundle $E_{(r,k)}$ on \mathbb{P}^n , $r \geq n - 1$, which is the cohomology of a linear monad of type:

$$(4.3) \quad \mathcal{O}_{\mathbb{P}^n}(-1)^k \xrightarrow{f} \mathcal{O}_{\mathbb{P}^n}^{2k+r} \xrightarrow{g} \mathcal{O}_{\mathbb{P}^n}(1)^k.$$

In this case, $k = \dim H^1(E_{(r,k)}(-1))$ and is called the *charge* of $E_{(r,k)}$. $E_{(r,k)}$ is sometimes called a *k-instanton*.

According to [Fl00], the condition $r \geq n - 1$ is equivalent to the existence of a monad of type (4.3). It should be noted however that it is not always the case that $E_{(r,k)}$ is a vector bundle; again from [Fl00] we learn that the degeneracy locus of the map f has *expected* codimension $r + 1$. Thus when dealing with such monads it will be necessary to check that this expected dimension indeed corresponds to the effective dimension.

Figures 4a to 4e are examples of sizes and ranks of matrices that can arise from generalized instantons.

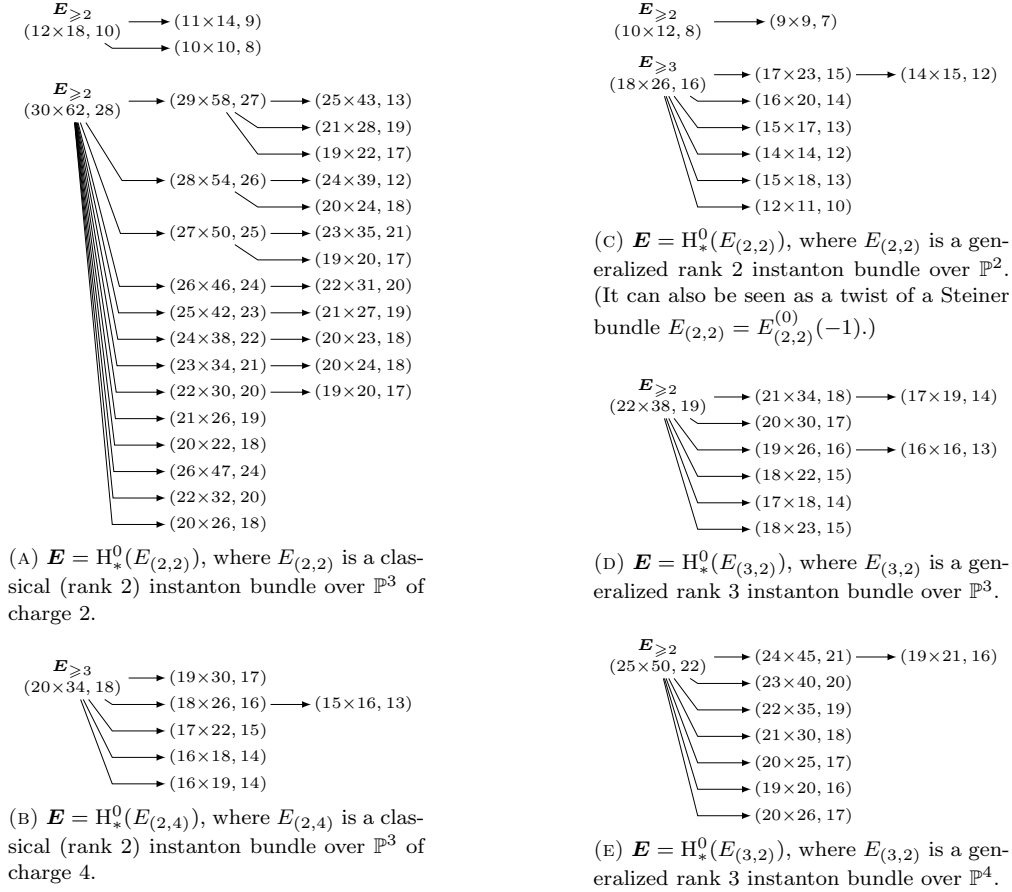

FIGURE 4. Examples of possible constant rank matrices that can be obtained from instanton and Steiner bundles. The notation is the same as in Figure 3.

4.4. Null correlation, Tango, and the Horrocks-Mumford bundle. Null correlation bundles are examples of rank $n - 1$ bundles on \mathbb{P}^n for n odd: they are constructed as kernel of the bundle epimorphism $T_{\mathbb{P}^n}(-1) \rightarrow \mathcal{O}_{\mathbb{P}^n}(1)$. A construction due to Ein [Ein88] generalizes this definition on \mathbb{P}^3 :

Definition 4.3. [Ein88] A rank 2 vector bundle $E_{(e,d,c)}$ on \mathbb{P}^3 is said to be a *generalized null correlation bundle* if it is given as the cohomology of a monad of the form:

$$\mathcal{O}_{\mathbb{P}^3}(-c) \rightarrow \mathcal{O}_{\mathbb{P}^3}(d) \oplus \mathcal{O}_{\mathbb{P}^3}(e) \oplus \mathcal{O}_{\mathbb{P}^3}(-e) \oplus \mathcal{O}_{\mathbb{P}^3}(-d) \rightarrow \mathcal{O}_{\mathbb{P}^3}(c),$$

where $c > d \geq e \geq 0$ are given integers.

Figures 5a to 5b show possible sizes of matrices appearing from null correlation bundles.

A construction of Tango [Tan76] produces an indecomposable rank $n - 1$ bundle over \mathbb{P}^n , for all \mathbb{P}^n , defined as a quotient E'_n of the dual of the kernel of the evaluation map of $\Omega_{\mathbb{P}^n}^1(2)$, which is a globally generated bundle. More in detail, one starts by constructing the rank $\binom{n}{2}$ bundle E_n

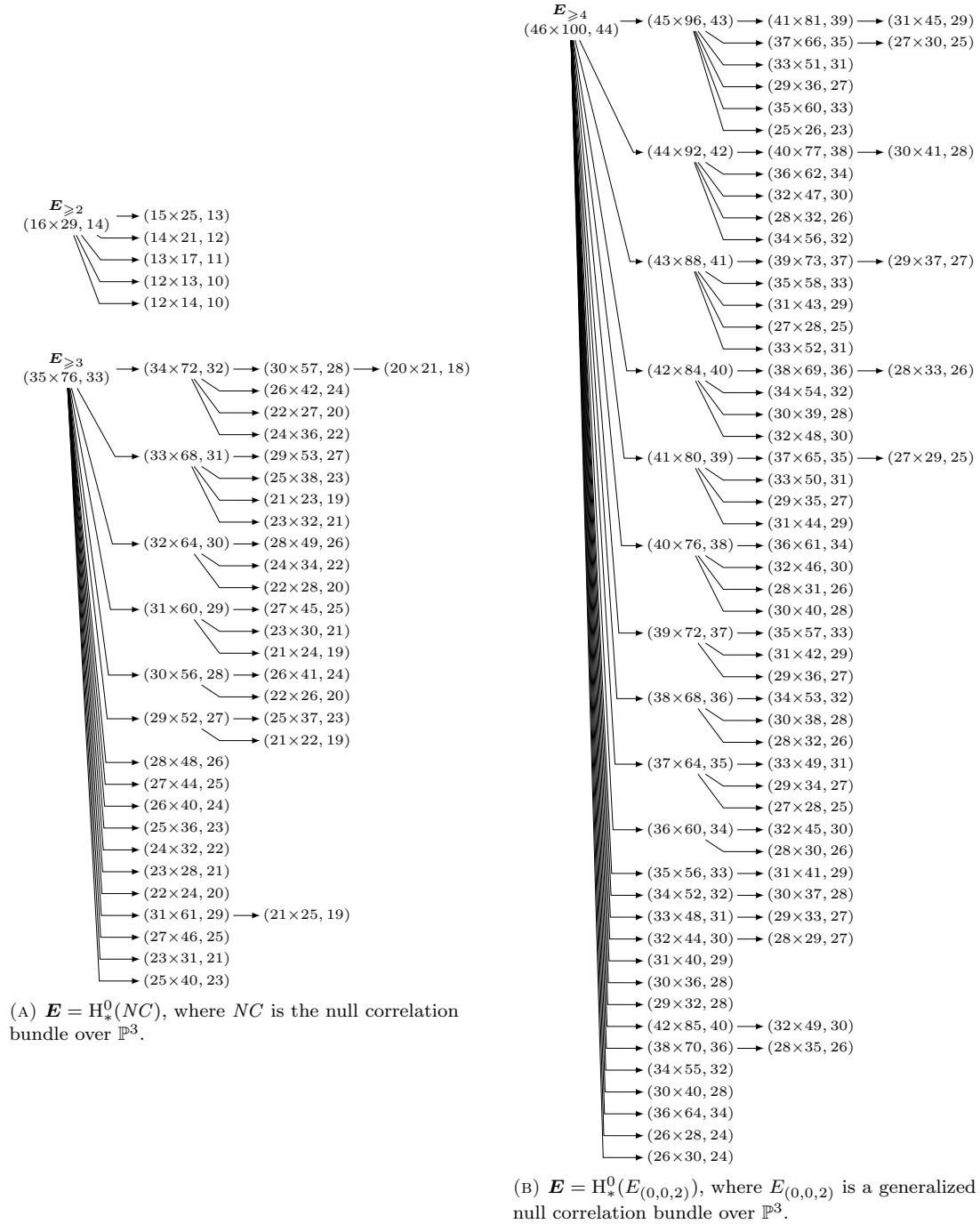

FIGURE 5. Size and rank of matrices of constant rank that can be constructed from null correlation bundles. The notation is the same as in Figure 3.

from the exact sequence:

$$(4.4) \quad 0 \rightarrow T_{\mathbb{P}^n}(-2) \rightarrow \mathcal{O}_{\mathbb{P}^n}^{\binom{n+1}{2}} \rightarrow E_n \rightarrow 0,$$

and then takes its quotient E'_n :

$$(4.5) \quad 0 \rightarrow \mathcal{O}_{\mathbb{P}^n}^{\binom{n}{2}-n} \rightarrow E_n \rightarrow E'_n \rightarrow 0,$$

that turns out to be a rank n indecomposable vector bundle on \mathbb{P}^n containing a trivial subbundle of rank 1. The Tango bundle F_n is defined as the quotient of E'_n by its trivial subbundle, and thus has rank $n - 1$.

Indecomposable rank $n - 2$ bundles on \mathbb{P}^n are even more difficult to construct; on \mathbb{P}^4 there is essentially only one example known, whose construction is due to Horrocks and Mumford [HM73]. It is an indecomposable rank 2 bundle that can be defined as the cohomology of the monad:

$$\mathcal{O}_{\mathbb{P}^4}(-1)^5 \rightarrow (\Omega_{\mathbb{P}^4}^2(2))^2 \rightarrow \mathcal{O}_{\mathbb{P}^4}^5.$$

Figures 6a and 6b show possible examples of constant rank matrices that can be constructed starting from Tango and the Horrocks-Mumford bundle.

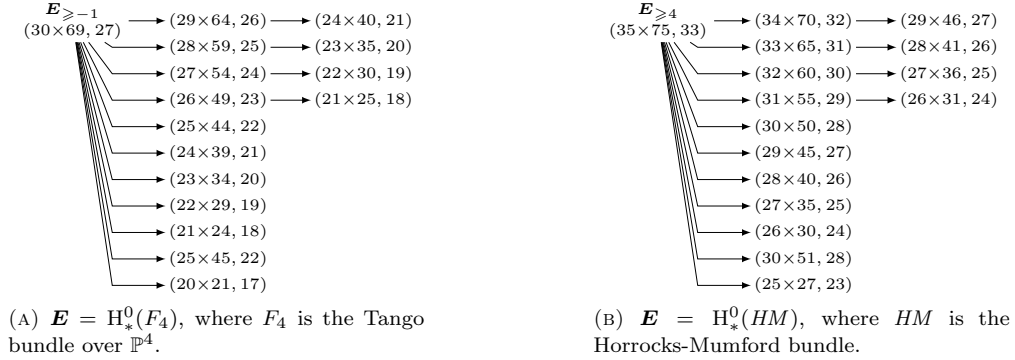

FIGURE 6. Examples of size and rank of matrices that can be constructed from Tango and Horrocks-Mumford bundles. The notation is the same as in Figure 3.

5. SKEW-SYMMETRIC MATRICES

In this section we consider linear matrices of constant rank with extra symmetry properties. The kernel and cokernel sheaves K and E of such a matrix are tightly related to one another, and the matrix itself is expressed by an extension class $\text{Ext}^2(E, K)$, that we already met in section 2. Let us connect this with our previous results.

Definition 5.1. Let E and K be vector bundles on \mathbb{P}^n . For $t \in \mathbb{Z}$, consider the Yoneda map:

$$v_t : H^0(E(t)) \otimes \text{Ext}^2(E, K) \rightarrow H^2(K(t)).$$

Set $\mathbf{E} = H_*^0(E)$ and $\mathbf{M} = H_*^2(K)$. Define Φ as the linear map induced by the v_t :

$$\Phi : \text{Ext}^2(E, K) \longrightarrow \text{Hom}_R(\mathbf{E}, \mathbf{M})_0.$$

Theorem 5.1. *Assume $n \geq 3$ and let $A : R(-m-1)^b \rightarrow R(-m)^a$ be skew-symmetrizable of constant rank. Set $K = \ker A$ and $E = \operatorname{coker} A$. Then $K \simeq E^*(-2m-1)$, and there is an element η lying in $H^2(S^2E^*(-2m-1))$ under the canonical decomposition*

$$\operatorname{Ext}^2(E, E^*(-2m-1)) \simeq H^2(S^2E^*(-2m-1)) \oplus H^2(\wedge^2E^*(-2m-1)),$$

such that A presents $\ker \Phi(\eta)$. Conversely, if $\eta \in H^2(S^2E^*(-2m-1))$, $\mu = \Phi(\eta)$ satisfies the assumptions of Theorem 1.2, and $\ker A \simeq E^*(-2m-1)$, then A is skew-symmetrizable.

The same holds for a symmetrizable A , once the above condition on η is replaced with $\eta \in H^2(\wedge^2E^*(-2m-1))$.

Proof. Let us check the first statement. Assume thus that A is skew-symmetric. Then, sheafifying the matrix A provided by Theorem 1.2 we get a long exact sequence of type (2.1), where we have already noticed that, since A has constant rank, E and K are locally free. Hence:

$$\mathcal{E}xt^i(E, \mathcal{O}_{\mathbb{P}^n}) = \mathcal{E}xt^i(K, \mathcal{O}_{\mathbb{P}^n}) = 0,$$

for all $i > 0$. Therefore, dualizing the above sequence and twisting by $\mathcal{O}_{\mathbb{P}^n}(-2m-1)$ we get:

$$0 \longrightarrow E^*(-2m-1) \longrightarrow \mathcal{O}_{\mathbb{P}^n}(-m-1)^a \xrightarrow{-A} \mathcal{O}_{\mathbb{P}^n}(-m)^a \longrightarrow K^*(-2m-1) \longrightarrow 0$$

Since the image \mathcal{E} of A is the same as the image of $-A$, these exact sequences can be put together to get $K \simeq E^*(-2m-1)$. We may thus rewrite them as:

$$0 \longrightarrow E^*(-2m-1) \longrightarrow \mathcal{O}_{\mathbb{P}^n}(-m-1)^a \xrightarrow{A} \mathcal{O}_{\mathbb{P}^n}(-m)^a \longrightarrow E \longrightarrow 0.$$

This long exact sequence represents an element $\eta \in \operatorname{Ext}^2(E, E^*(-2m-1)) \simeq H^2(E^* \otimes E^*(-2m-1))$. By looking at the construction of [BFM13, Lemma 3.1], it is now clear that for A to be skew-symmetric η should lie in $H^2(S^2E^*(-2m-1))$.

To understand why A presents $\ker \Phi(\eta)$, let us first expand some details of the definition of Φ . Let again \mathcal{E} be the image of A and write for any integer t the exact commutative diagram:

$$\begin{array}{ccccccc} 0 & \longrightarrow & K(t) & \longrightarrow & \mathcal{O}_{\mathbb{P}^n}(-m-1+t)^a & \xrightarrow{A} & \mathcal{O}_{\mathbb{P}^n}(-m+t)^a & \longrightarrow & E(t) & \longrightarrow & 0. \\ & & & & & & \searrow & & \nearrow & & \\ & & & & & & \mathcal{E}(t) & & & & \\ & & & & \nearrow & & & & \searrow & & \\ 0 & & & & & & & & & & 0 \end{array}$$

Taking cohomology, we get maps:

$$(5.1) \quad \begin{array}{ccc} \mu_t : H^0(E(t)) & \longrightarrow & H^2(K(t)). \\ & \searrow & \nearrow \\ & & H^1(\mathcal{E}(t)) \end{array}$$

Remark that sequence (2.1) corresponds to $\eta \in \operatorname{Ext}^2(E, K)$. Cup product with η induces via Yoneda's composition the linear maps μ_t 's of (5.1). But these maps are obtained from the v_t by transposition, so cup product with η gives:

$$\mu = \oplus_t \mu_t = \Phi(\eta) : H_*^0(E) = \mathbf{E} \rightarrow \mathbf{M} = H_*^2(E^*(-2m-1)).$$

This is obviously a morphism, homogeneous of degree 0. Notice that as soon as $n \geq 3$, both groups $H^1(\mathcal{O}_{\mathbb{P}^n}(-m+t))$ and $H^2(\mathcal{O}_{\mathbb{P}^n}(-m-1+t))$ vanish for all values of t , hence μ is surjective. By construction A appears as presentation matrix of $\mathbf{F} = \ker \mu$.

For the converse statement, the element η corresponds to a length-2 extension of $E^*(-2m-1)$ by E . Set $\mu = \Phi(\eta)$. Theorem 1.2 gives a linear matrix A of constant rank presenting $\mathbf{F} = \ker \mu$. Note that sheafifying \mathbf{F} we get back the bundle E , as $\mathbf{M} = H^2(E^*(-2m-1))$ is Artinian. On the other hand, since $\ker A \simeq E^*(-2m-1)$, the matrix A represents the extension class η . Therefore, A is skew-symmetrizable by [BFM13, Lemma 3.5 (iii)]. Part (i) of the same lemma says that, when

dealing with symmetric matrices, one should replace the condition $\eta \in \mathbb{H}^2(S^2 E^*(-2m-1))$ with $\eta \in \mathbb{H}^2(\wedge^2 E^*(-2m-1))$. The theorem is thus proved. \square

In particularly favorable situations, for instance when E is an instanton bundle of charge 2 (cf. [BFM13, Theorem 5.2]), or a generic instanton bundle of charge 4 (cf. [BFM13, Theorem 6.1]), one can check that the map Φ is a surjection. This makes the search for an element η corresponding to a skew-symmetric matrix of the prescribed size and constant rank considerably easier.

Example 5.1. Let us work out the case of generic instantons of rank 2, and write down an explicit 10×10 skew-symmetric matrix of constant rank 8. Let E be a rank 2 instanton bundle of charge 2 on \mathbb{P}^3 , obtained as cohomology of a monad of type (4.3). We take a special 2-istanton, as described in [AO95]; its monad has maps:

$$f = \begin{bmatrix} 0 & x_1 \\ x_1 & x_0 \\ x_0 & 0 \\ 0 & -x_3 \\ -x_3 & -x_2 \\ -x_2 & 0 \end{bmatrix} \quad \text{and} \quad g = \begin{bmatrix} x_2 & x_3 & 0 & x_0 & x_1 & 0 \\ 0 & x_2 & x_3 & 0 & x_0 & x_1 \end{bmatrix}.$$

Once the bundle E is constructed, let $\mathbf{E} := \mathbb{H}_*^0(E)$ be its module of sections, having resolution:

$$0 \rightarrow R(-4)^2 \rightarrow R(-3)^6 \rightarrow R(-2)^4 \oplus R(-1)^2 \rightarrow \mathbf{E} \rightarrow 0.$$

We truncate it in degree $m = 2$ in order to get a 2-linear resolution; then we take the 2nd graded cohomology module $\mathbb{H}_*^2(E)$, which is a module of length 2, and we set $\mathbf{G} := (\mathbb{H}_*^2(E)(-5))_{\geq 2}$. The truncated module \mathbf{G} has length 1. The resolutions of these two modules are

$$\begin{aligned} 0 &\longrightarrow R(-5)^2 \longrightarrow R(-4)^{10} \longrightarrow R(-3)^{18} \longrightarrow R(-2)^{12} \longrightarrow \mathbf{E}_{\geq 2} \longrightarrow 0, \\ 0 &\longrightarrow R(-6)^2 \longrightarrow R(-5)^8 \longrightarrow R(-4)^{12} \longrightarrow R(-3)^8 \longrightarrow R(-2)^2 \longrightarrow \mathbf{G} \longrightarrow 0. \end{aligned}$$

The hypotheses of Theorem 1.1(ii) cannot be satisfied and the presentation of $\ker \mu_2$ for a generic morphism $\mu_2 : \mathbf{E}_{\geq 2} \rightarrow \mathbf{M}$ is not linear:

$$\begin{array}{c} R(-4)^2 \\ \oplus \\ R(-3)^{10} \end{array} \longrightarrow R(-2)^{10} \longrightarrow \ker \mu_2 \longrightarrow 0.$$

Nevertheless, μ_2 satisfies the hypothesis of Theorem 1.2(ii). Hence, if we restrict to the linear part of the presentation $A : R(-3)^{10} \rightarrow R(-2)^{10}$, we obtain a 10×10 matrix of constant rank 8.

Such a matrix A does not enjoy any particular symmetry property. But if we can make sure that the map $\mathbf{E} \rightarrow \mathbf{M}$ comes indeed from an element of $\mathbb{H}^2(S^2 E^*(-5))$, then Theorem 5.1 will guarantee that this matrix is skew-symmetrizable. By [BFM13, Theorem 5.2] we know that $\mathbb{H}^2(S^2 E^*(-5))$ surjects onto $\text{Hom}_R(\mathbf{E}, \mathbb{H}_*^2(E)(-5))_0$, and in fact any element there will have the same kernel as its truncation in degree 2 μ_2 , because the map is an isomorphism in degree 1. We can thus take a random element in $\text{Hom}_R(\mathbf{E}, \mathbb{H}_*^2(E)(-5))_0$ and our construction will work without us having to truncate. An explicit example of this procedure yields the matrix $A = A_0 x_0 + A_1 x_1 + A_2 x_2 + A_3 x_3$,

where:

$$\begin{aligned}
 A_0 &= \begin{bmatrix} 0 & 108 & 594 & 54 & 36 & 876 & 108 & 18 & 0 & 0 \\ & 0 & 0 & 0 & -18 & 192 & 0 & -36 & 0 & 0 \\ & & 0 & 0 & 36 & 192 & 0 & 18 & 0 & 0 \\ & & & 0 & 0 & 0 & 0 & 0 & 0 & 0 \\ & & & & 0 & 18 & 18 & 0 & 0 & 0 \\ & & & & & 0 & -48 & -36 & 0 & 0 \\ & & & & & & 0 & -36 & 0 & 0 \\ & & & & & & & 0 & 0 & 0 \\ & & & & & & & & 0 & 0 \\ & & & & & & & & & 0 \end{bmatrix}, \\
 A_1 &= \begin{bmatrix} 0 & -324 & 162 & 0 & -64 & -492 & -324 & -\frac{193}{4} & 0 & 0 \\ & 0 & 0 & 0 & -16 & 48 & 0 & -\frac{41}{2} & 0 & 0 \\ & & 0 & 0 & -16 & 264 & 0 & -\frac{163}{4} & 0 & 0 \\ & & & 0 & 0 & 24 & 0 & -\frac{9}{4} & 0 & 0 \\ & & & & 0 & 16 & 4 & 0 & 0 & 0 \\ & & & & & 0 & -48 & -\frac{89}{2} & 0 & 0 \\ & & & & & & 0 & -\frac{17}{2} & 0 & 0 \\ & & & & & & & 0 & \frac{27}{2} & 0 \\ & & & & & & & & 0 & 0 \\ & & & & & & & & & 0 \end{bmatrix}, \\
 A_2 &= \begin{bmatrix} 0 & -438 & -534 & -108 & -36 & -1590 & -\frac{495}{2} & -36 & -324 & 54 \\ & 0 & 300 & 0 & 18 & 0 & -75 & 18 & 0 & 0 \\ & & 0 & -54 & -36 & -876 & -\frac{705}{2} & -36 & 0 & 0 \\ & & & 0 & 0 & 0 & -\frac{27}{2} & 0 & 0 & 0 \\ & & & & 0 & -18 & -18 & 0 & 0 & 0 \\ & & & & & 0 & -219 & 18 & 0 & 0 \\ & & & & & & 0 & 18 & 81 & 0 \\ & & & & & & & 0 & 0 & 0 \\ & & & & & & & & 0 & 0 \\ & & & & & & & & & 0 \end{bmatrix}, \\
 \text{and } A_3 &= \begin{bmatrix} 0 & -498 & 978 & \frac{319}{4} & 64 & \frac{1058}{3} & -438 & 64 & 0 & 0 \\ & 0 & 612 & \frac{23}{2} & 16 & \frac{388}{3} & -48 & 16 & 0 & 0 \\ & & 0 & -\frac{35}{4} & 16 & -\frac{2116}{3} & -444 & 16 & 0 & 0 \\ & & & 0 & 0 & -\frac{23}{2} & \frac{1}{2} & 0 & \frac{27}{2} & 0 \\ & & & & 0 & -16 & -4 & 0 & 0 & 0 \\ & & & & & 0 & -\frac{128}{3} & 16 & 144 & -24 \\ & & & & & & 0 & 4 & 0 & 0 \\ & & & & & & & 0 & 0 & 0 \\ & & & & & & & & 0 & 0 \\ & & & & & & & & & 0 \end{bmatrix}.
 \end{aligned}$$

ACKNOWLEDGEMENTS

We would like to express our gratitude to Emilia Mezzetti for introducing us to this problem. We thank Philippe Ellia for pointing out a mistake in a previous version of this paper. The current version of our main results are deeply inspired on his remarks.

REFERENCES

- [AHDM78] M. F. Atiyah, N. J. Hitchin, V. G. Drinfel'd, and Y. I. Manin, *Construction of instantons*, Phys. Lett. A **65** (1978), no. 3, 185–187.
- [AO95] V. Ancona and G. Ottaviani, *On moduli of instanton bundles on \mathbf{P}^{2n+1}* , Pacific J. Math. **171** (1995), no. 2, 343–351.
- [BFM13] A. Boralevi, D. Faenzi, and E. Mezzetti, *Linear spaces of matrices of constant rank and instanton bundles*, Adv. Math. **248** (2013), 895–920.
- [BM15] A. Boralevi and E. Mezzetti, *Planes of matrices of constant rank and globally generated vector bundles*, Ann. Inst. Fourier **65** (2015), no. 5, 2069–2089.

- [BS08] M. Boij and J. Söderberg, *Graded Betti numbers of Cohen-Macaulay modules and the multiplicity conjecture*, J. Lond. Math. Soc. (2) **78** (2008), no. 1, 85–106.
- [EFW11] D. Eisenbud, G. Fløystad, and J. Weyman, *The existence of equivariant pure free resolutions*, Ann. Inst. Fourier (Grenoble) **61** (2011), no. 3, 905–926.
- [EH88] D. Eisenbud and J. Harris, *Vector spaces of matrices of low rank*, Adv. in Math. **70** (1988), no. 2, 135–155.
- [Ein88] L. Ein, *Generalized null correlation bundles*, Nagoya Math. J. **111** (1988), 13–24.
- [ES09] D. Eisenbud and F-O. Schreyer, *Betti numbers of graded modules and cohomology of vector bundles*, J. Amer. Math. Soc. **22** (2009), no. 3, 859–888.
- [ESS] D. Eisenbud, F-O. Schreyer, and M. Stillman, *BoijSoederberg*, a *Macaulay2* package available at <http://www.math.uiuc.edu/Macaulay2/doc/Macaulay2-1.8.2/share/doc/Macaulay2/BoijSoederberg/html/>.
- [Flø00] G. Fløystad, *Monads on projective spaces*, Comm. Algebra **28** (2000), no. 12, 5503–5516, Special issue in honor of Robin Hartshorne.
- [FM11] M.L. Fania and E. Mezzetti, *Vector spaces of skew-symmetric matrices of constant rank*, Linear Algebra Appl. **434** (2011), 2383–2403.
- [GS] D.R. Grayson and M.E. Stillman, *Macaulay2, a software system for research in algebraic geometry*, Available at <http://www.math.uiuc.edu/Macaulay2/>.
- [HM73] G. Horrocks and D. Mumford, *A rank 2 vector bundle on P^4 with 15,000 symmetries*, Topology **12** (1973), 63–81. MR 0382279
- [IL99] B. Ilic and J.M. Landsberg, *On symmetric degeneracy loci, spaces of symmetric matrices of constant rank and dual varieties*, Math. Ann. **314** (1999), no. 1, 159–174.
- [Jar06] M. Jardim, *Instanton sheaves on complex projective spaces*, Collect. Math. **57** (2006), no. 1, 69–91.
- [OS86] C. Okonek and H. Spindler, *Mathematical instanton bundles on P^{2n+1}* , J. Reine Angew. Math. **364** (1986), 35–50.
- [OSS80] C. Okonek, M. Schneider, and H. Spindler, *Vector bundles on complex projective spaces*, Progress in Mathematics, no. 3, Birkhäuser, Boston, 1980.
- [Pee11] I. Peeva, *Graded syzygies*, Algebra and Applications, vol. 14, Springer-Verlag London, Ltd., London, 2011.
- [Syl86] J. Sylvester, *On the dimension of spaces of linear transformations satisfying rank conditions*, Linear Algebra Appl. **78** (1986), 1–10.
- [Tan76] H. Tango, *An example of indecomposable vector bundle of rank $n - 1$ on P^n* , J. Math. Kyoto Univ. **16** (1976), no. 1, 137–141.
- [Wes87] R. Westwick, *Spaces of matrices of fixed rank*, Lin. and Multilin. Algebra **20** (1987), no. 2, 171–174.
- [Wes90] ———, *Examples of constant rank spaces*, Lin. and Multilin. Algebra **28** (1990), 155–174.
- [Wes96] ———, *Spaces of matrices of fixed rank. II*, Linear Algebra Appl. **235** (1996), 163–169.

SCUOLA INTERNAZIONALE SUPERIORE DI STUDI AVANZATI, VIA BONOMEA 265, 34136 TRIESTE, ITALY
E-mail address: ada.boralevi@sissa.it

INSTITUT DE MATHÉMATIQUES DE BOURGOGNE, UMR CNRS 5584, UNIVERSITÉ DE BOURGOGNE, 9 AVENUE ALAIN SAVARY, BP 47870, 21078 DIJON CEDEX, FRANCE
E-mail address: daniele.faenzi@u-bourgogne.fr

DIPARTIMENTO DI MATEMATICA, UNIVERSITÀ DEGLI STUDI DI TRENTO, VIA SOMMARIVE 14, 38123 TRENTO, ITALY
E-mail address: paolo.lella@unitn.it
URL: <http://www.paololella.it/>